

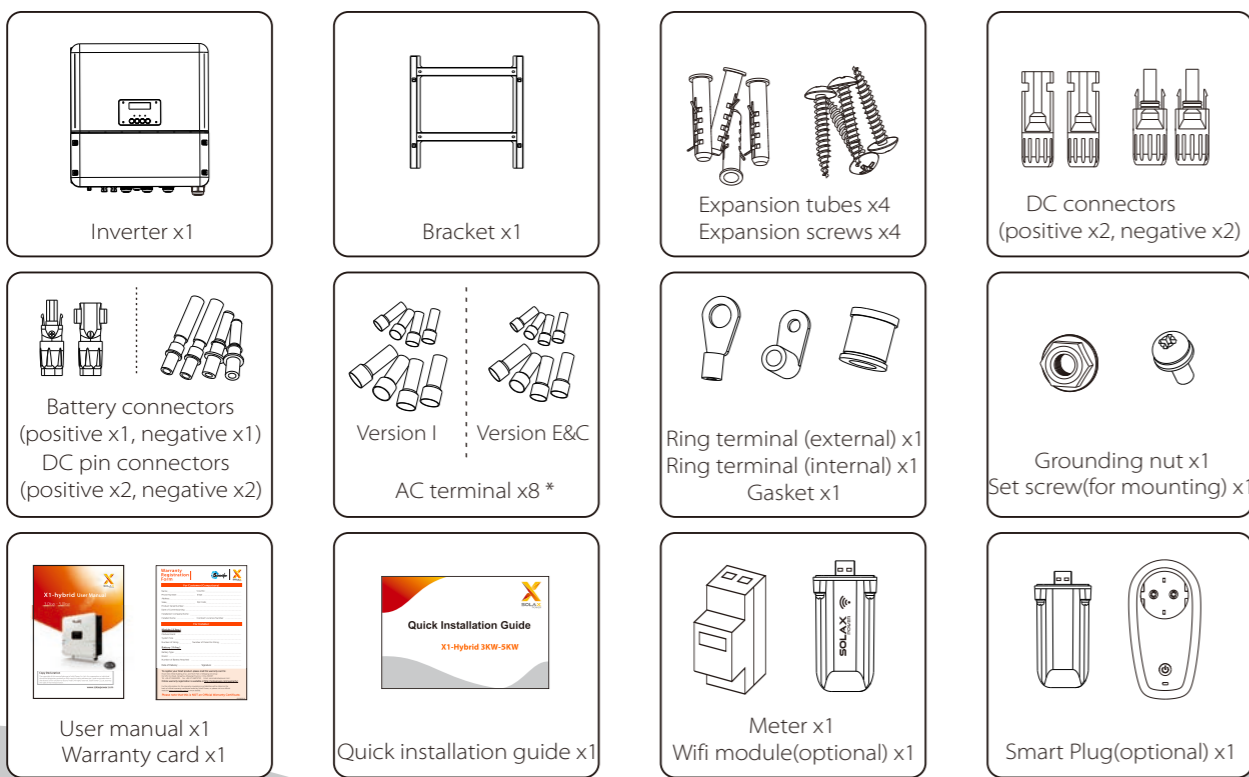

Quick Installation Guide

X1-Hybrid 3KW-5KW

I Packing List



AC terminal x8*: 4 6AWG AC terminals and 4 10AWG AC terminals for Version I
4 10AWG AC terminals and 4 8AWG AC terminals for Version E and Version C

IV EPS Connection(for I version and E version)

EPS wiring diagram

I Version inverter: EPS function can be only achieved automatically. Do not required for Changeover Switch.

- I Version • Auto • Do not required for Changeover Switch

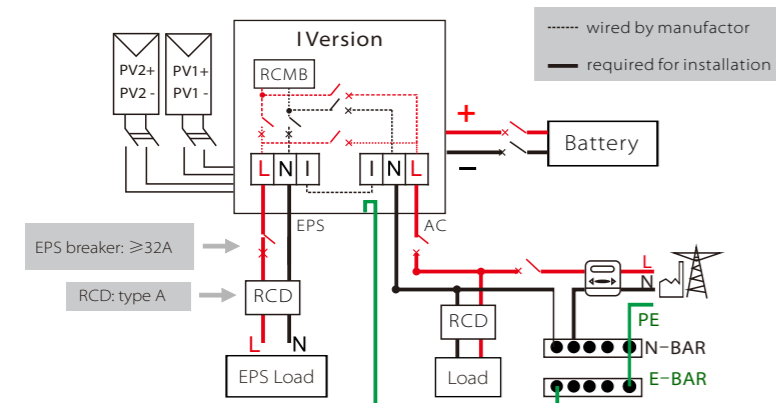

E Version inverter: EPS function can be achieved manually or automatically.

- E Version • Manual • Required for Changeover Switch

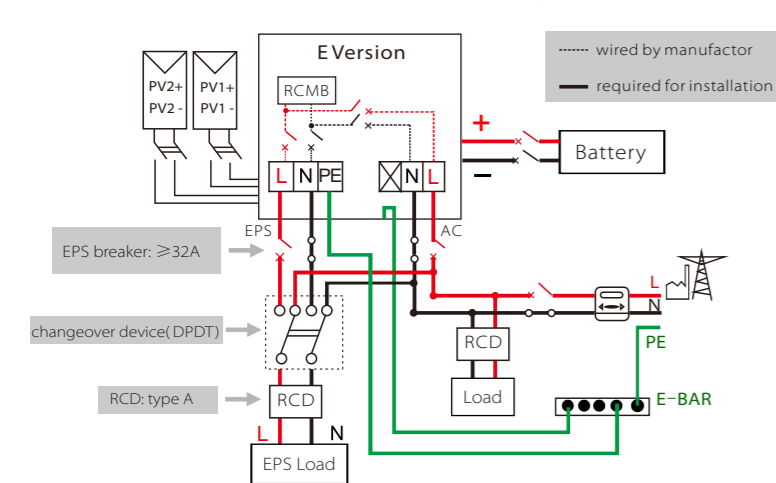

- E Version • Auto • Required for Changeover Switch

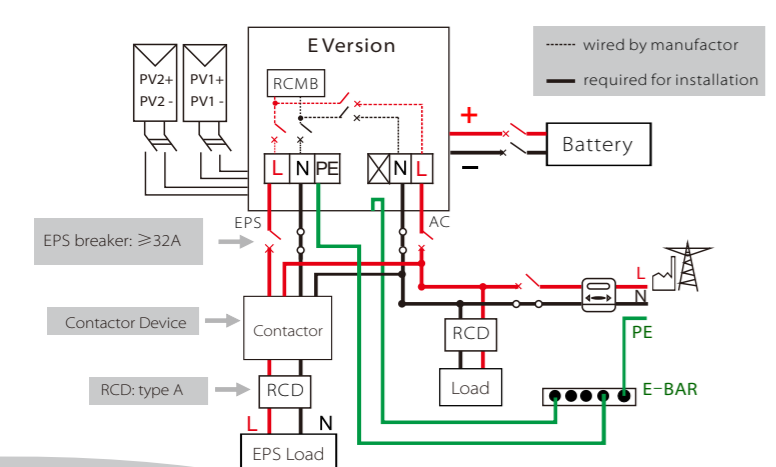

Please contact our sales for any compatible contactor-purchase requirement.

EPS connection steps:

1. Make wires(EPS cable size: refer to the table below)

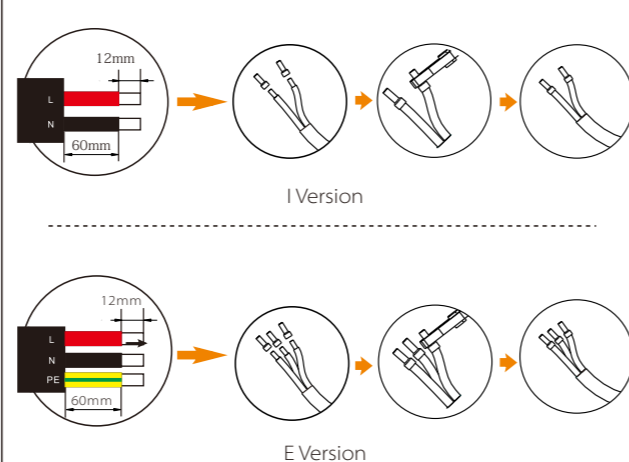

Model	X1-Hybrid-3.0-D	X1-Hybrid-3.7-D	X1-Hybrid-4.6-D	X1-Hybrid-5.0-D
EPS Cable	≥5mm ²	≥5mm ²	≥5mm ²	≥5mm ²
EPS breaker	25A	25A	32A	32A

table. Cable and Micro-breaker recommended

2. Insert EPS cable into EPS port through screw cap.

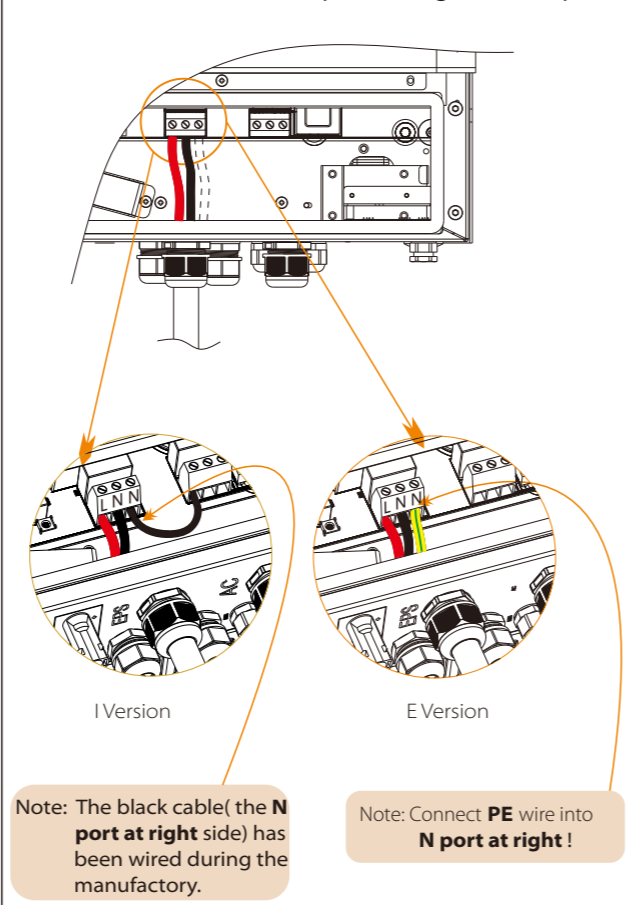

Note: The black cable (the N port at right side) has been wired during the manufactory.

Note: Connect PE wire into N port at right!

II Mounting Steps

- Mark position of four holes.
- Drill holes with φ10 drill. Depth: at least 60mm.
- Tighten the expansion tubes. Screw the expansion screws.

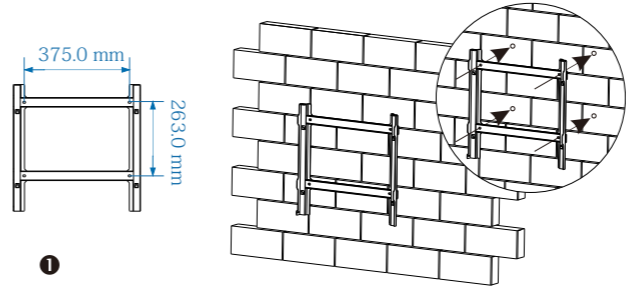

- Match the inverter with the bracket.

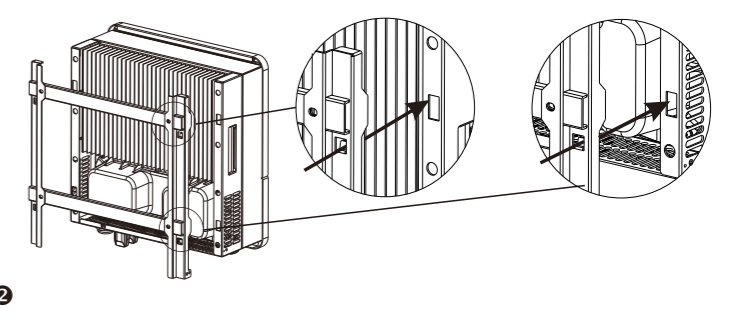

- Screw the set screw on the left-bottom of inverter tightly.

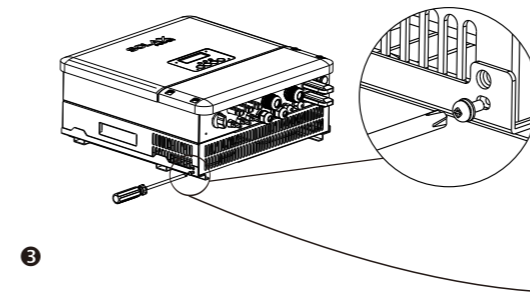

- If necessary, customer can install an anti-theft lock on the left-bottom of the inverter.

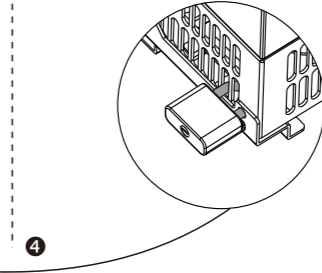

- Overview of Mounting

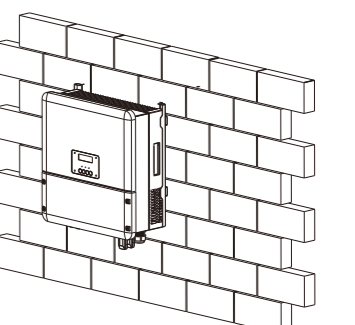

III PV and AC Connection

PV connection steps(PV cable size:12AWG):

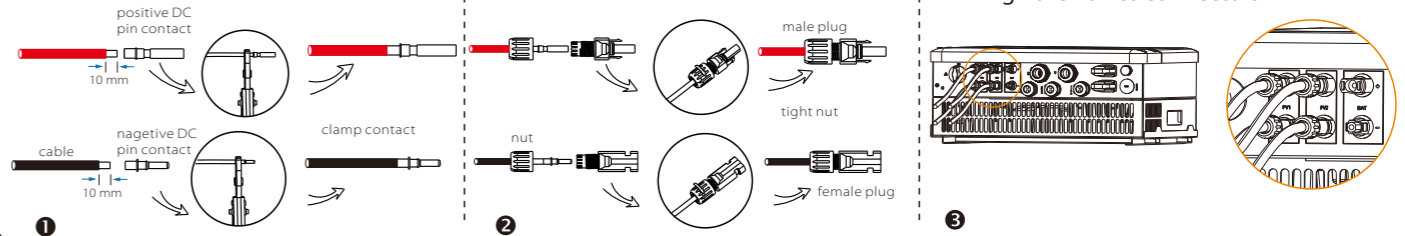

AC connection steps(AC cable size: refer to table1&table2):

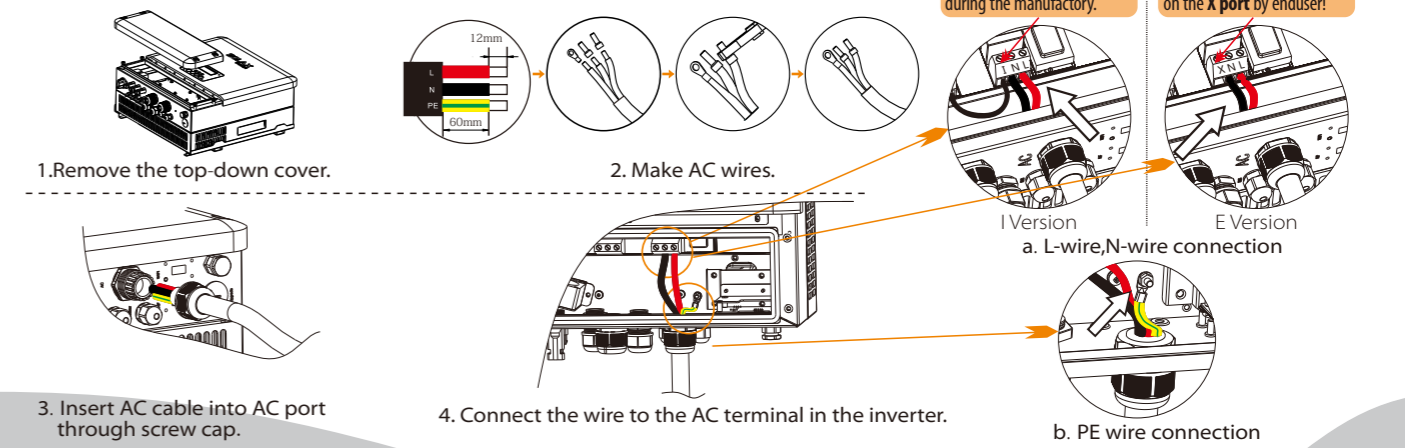

Model	X1-Hybrid-3.0-D	X1-Hybrid-3.7-D	X1-Hybrid-4.6-D	X1-Hybrid-5.0-D
Cable	4-5mm ²	4-5mm ²	5-6mm ²	5-6mm ²
Micro-breaker	20A	20A	32A	32A

table1. E Version & C Version

Model	X1-Hybrid-3.0-D	X1-Hybrid-3.7-D	X1-Hybrid-4.6-D	X1-Hybrid-5.0-D
Cable	8-10mm ²	8-10mm ²	10-13mm ²	10-13mm ²
Micro-breaker	50A	50A	63A	63A

table2. I Version

V Battery Connection

Battery connection diagram

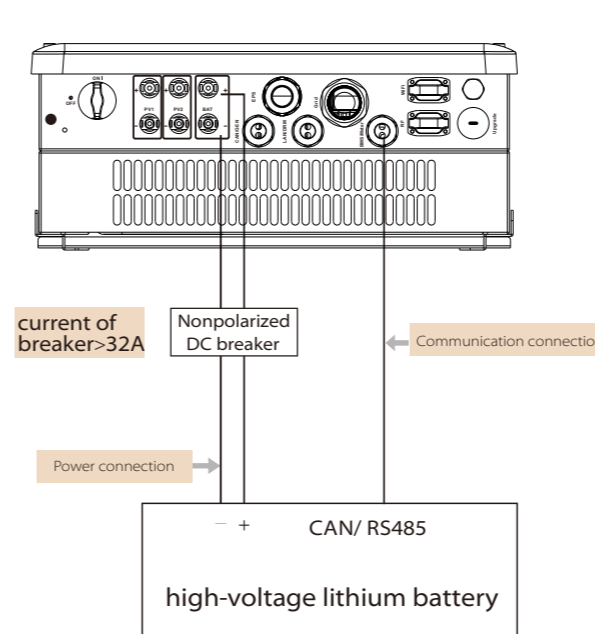

Battery breaker

Before connecting to battery, please install a nonpolarized DC breaker to make sure inverter can be securely disconnected during maintenance.

Model	X1-Hybrid-3.0-D	X1-Hybrid-3.7-D	X1-Hybrid-4.6-D	X1-Hybrid-5.0-D
Voltage	Nominal voltage of DC breaker should be larger than maximum voltage of battery.			
Current[A]	32A			

BMS PIN Definition

Communication interface between inverter and battery is RS485 or CAN with a RJ45 connector.

PIN	1	2	3	4	5	6	7	8
CAN Definition	X	GND	X	BMS_CANH	BMS_CANL	X	X	X
RS485 Definition	X	X	X	X	X	GND	BMS_485A	BMS_485B

When using RS485 protocol, please note that PIN2 must be disconnected.

Note: The battery communication can only work when the battery BMS is compatible with the inverter.

A:Power Connection Steps:

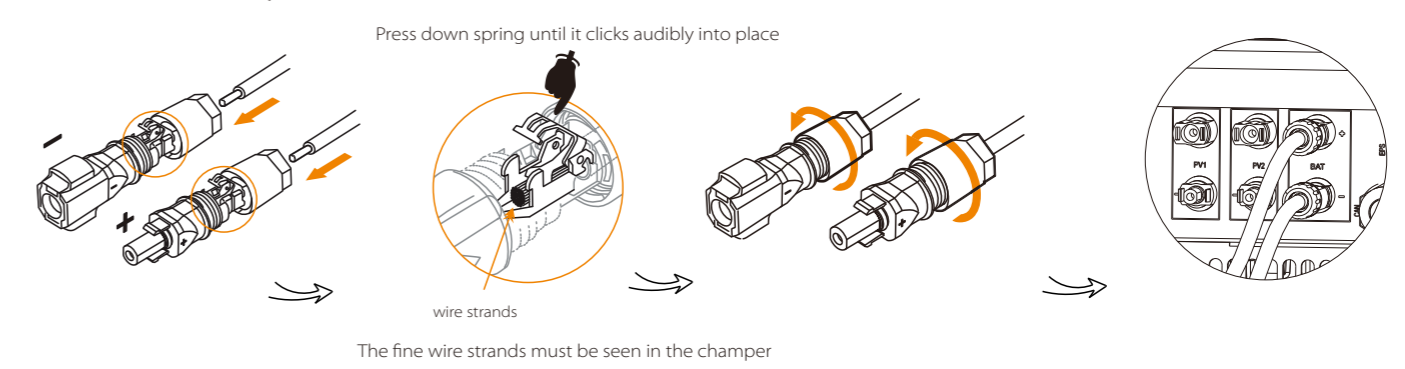

B:Communication Connection Steps:

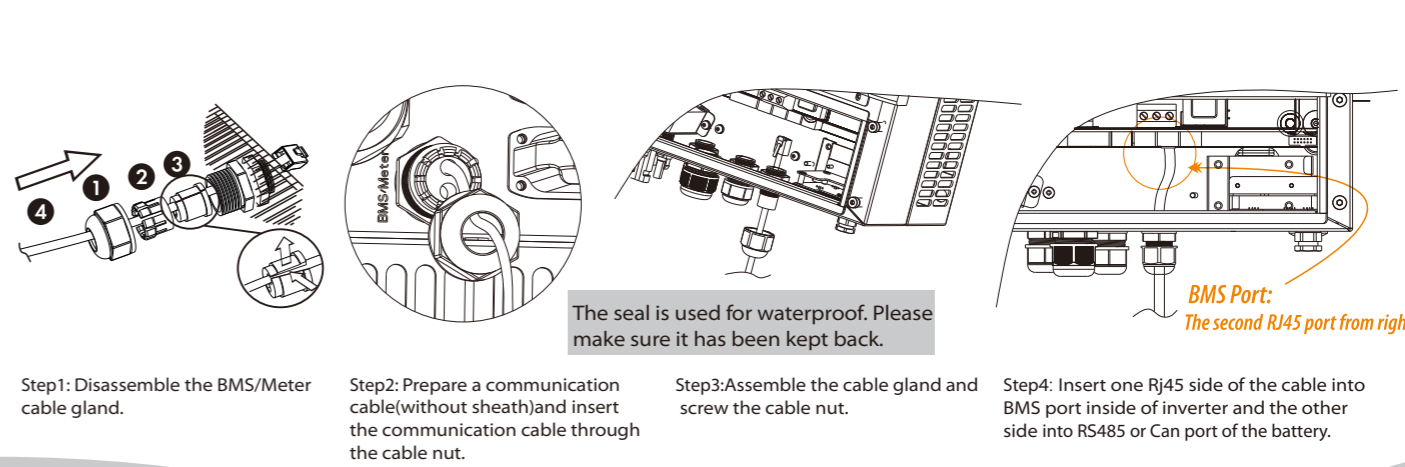

Step1: Disassemble the BMS/Meter cable gland.

Step2: Prepare a communication cable(without sheath)and insert the communication cable through the cable nut.

Step3:Assemble the cable gland and screw the cable nut.

Step4: Insert one RJ45 side of the cable into BMS port inside of inverter and the other side into RS485 or Can port of the battery.

BMS Port: The second RJ45 port from right

Earth Connection Steps(mandatory):

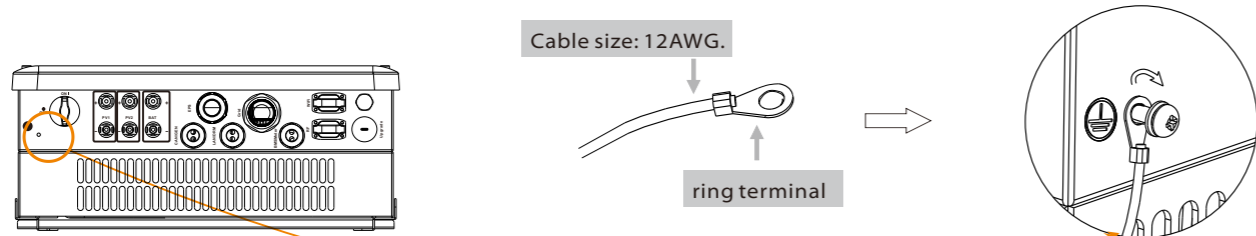

Cable size: 12AWG.

ring terminal

Start inverter

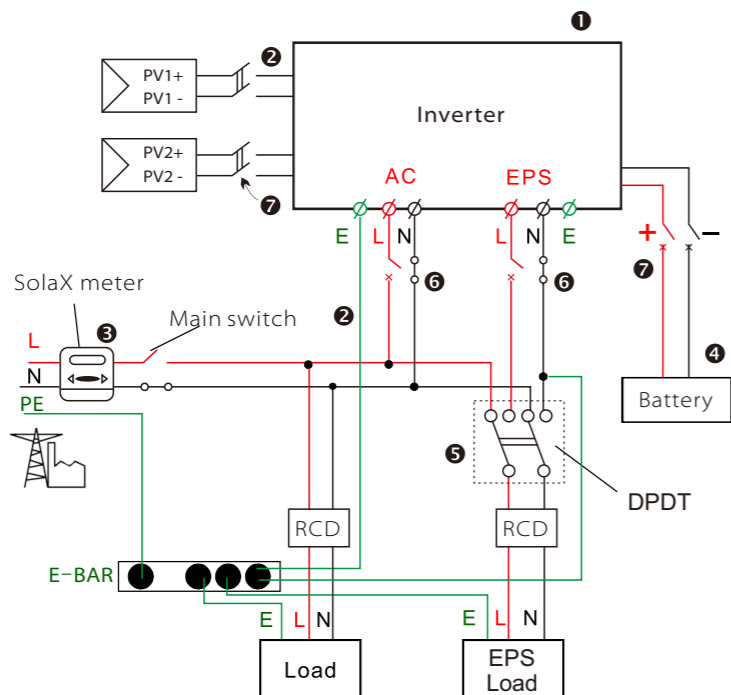

- ❶ Check the inverter is fixed well on the wall.
- ❷ Make sure all the DC wirings and AC wirings are completed.
- ❸ Make sure the meter is connected well.
- ❹ Make sure the battery is connected well.
- ❺ Make sure the external EPS contactor is connected well. (if needed)
- ❻ Turn on the AC switch and EPS switch.
- ❼ Turn on the PV/DC switch and battery switch.
- ❽ Press the "Enter" key for five seconds to exit Off Mode.(The mode is factory defaulted as Off Mode)

Inverter will start up automatically when the PV panels generate enough energy or the battery is discharging.

Check the status of indicators and LCD screen. The left indicator should be blue and the indicator screen should display the main interface.

1.Set language

Language
English
Deutsch
Italian

2.Set date time

Date time
2017 ->06 <-06
10:19

3.Set the safety standard

Safety
Country
>VDE0126

4.Set export control

Export Control
Use Value:
10000W

This function allows the inverter able to control energy exported to the grid. There are user value and factory value. The factory value is default which can not be changed by user. The user value setting by installer must be less than the factory value.

5.Set work mode

There are 4 work modes for choice.
Self use/ Back Up Mode/ Feed in Priority/ Force Time Use

Parameter	Comment
Self Use (default)	The PV generated power will be used to supply the local loads firstly, then to charge the battery. The redundant power will export to the public grid. When there is no PV supplied, battery will discharge for local loads firstly, and grid will supply power when the battery capacity is not enough.
Back Up Mode	Battery will stop discharging to keep higher capacity when the grid is on. Only when the grid is off and PV energy is not enough, battery will start to discharge to keep the emergency load working normally. This work mode applies to the area where suffering from blackout regularly.
Feed in Priority	The priority of inverter output power is: feeding to the grid → supplying the load → charging the battery. This work mode applies to the area with high feed-in tariff.
Force Time Use	In this work mode the charging and discharging time can be set flexibly, and it also allows to choose whether charge from the grid or not.

Work Mode

>Mode Select
self use

6.Set EPS system(For E & I Version only)

EPS system
> Mute: No
Frequency: 50Hz

X1-Hybrid inverter with E Version and I Version can work on the EPS mode. EPS parameters can be set as below.
- "Mute" means you can set the warning of system which has entered EPS mode.
- "No" means there will be a buzzing and it is the default value.
- "Yes" means you choose to shut down the warning function.

Besides, if the buzzing is sharp, it means EPS output is over loads.
Frequency here can be set 50Hz or 60Hz please based on correlative loads.

7.Set relay control(This function is being developed)

Relay Control
>Relay1 Setting
>Relay2 Setting

Relay Control is an optional function which can control designated load intelligently by consuming the surplus energy when feed in power reaches certain value.
This function can only be achieved with solax product "Smart Plug".
For specific operation, please refer to "Smart Plug user manual".

Meter Connection

Meter connection diagram

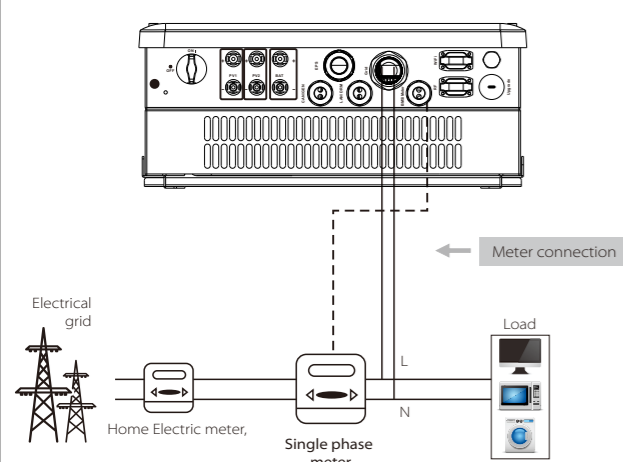

Meter PIN Definition

Communication interface between inverter and meter is RS485 with a RJ45 connector.

	1	2	3	4	5	6	7	8
	X	X	X	485A	485B	X	X	X

Meter connection steps:

Step1. Disassemble the BMS/Meter cable gland.
Step2. Prepare a communication cable(without sheath) and insert the communication cable through the cable nut.

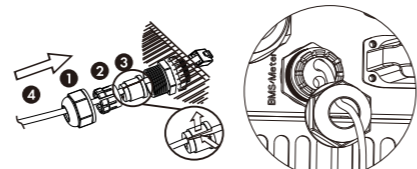

Step3. Assemble the cable gland and screw the cable nut.

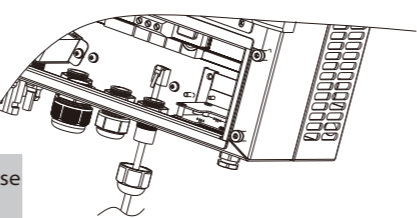

The seal is used for waterproof. Please make sure it has been kept back.

Step4. Insert one side of RJ45 cable into Meter port inside of the inverter and the other side into RS485 port of the meter.

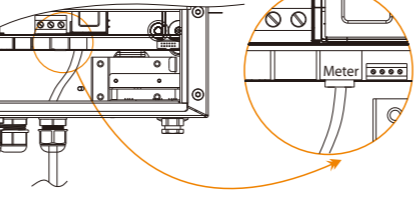

Meter Port: The first RJ45 port from right side

Monitoring Operation

Solax provides two ways for users to choose: WiFi(optional) and Ethernet(LAN)

WiFi(optional)

Inverter provides a WiFi port which can collect data from inverter and transmit it to monitoring-website via a Pocket WiFi. (Purchase the product from supplier if needed)

Diagram

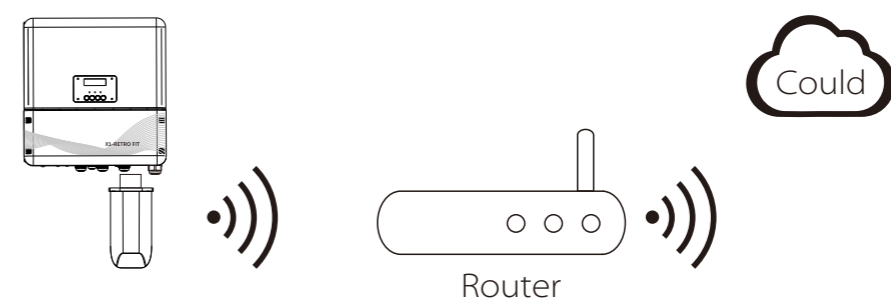

WiFi Connection Steps:

- Step1.** Plug Pocket Wifi into "WiFi" port at the bottom of the inverter.
- Step2.** Build the connection between the inverter and router.
- Step3.** Create an user account online. (Please check the Pocket WiFi user manual for more details.)

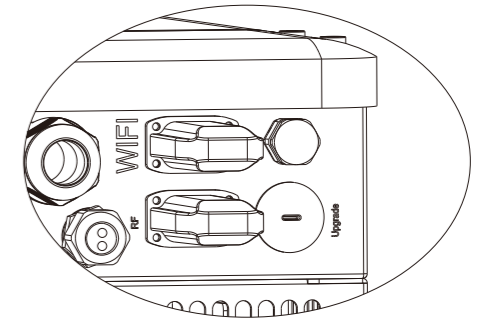

Ethernet(LAN)

LAN communication is the standard communication interface. It can transmit the data between the router and inverter via the local network.

Application Occasion

This function is applicable for the below situation:
When the wifi signal is too weak to transmit data, user can use LAN port for the monitoring with a data cable.
Note: The wifi module still needs to be connected when using LAN connection.

LAN PIN Definition

Communication interface between inverter and router is RS485 with a RJ45 connector.

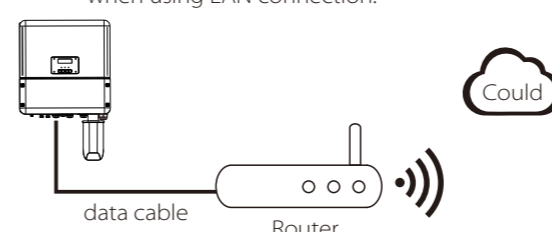

	1	2	3	4	5	6	7	8
	TX+	TX-	RX+	X	X	RX-	X	X

LAN Connection Steps:

Please refer to BMS connection steps (for user manual page32) for LAN connection. Please kindly noted the PIN definition and port position will be slightly different.



LAN/DRM Port

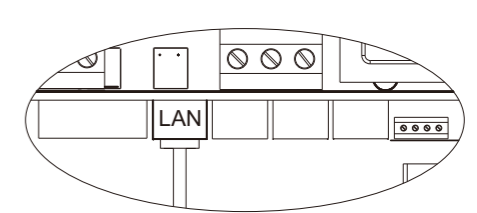

LAN Port: The Fourth RJ45 port from right side

Firmware Upgrading

Preparation

Please ensure the inverter is steadily powered on.
Inverter must connect PV panels and keep the battery on through whole procedure of upgrading.
Please prepare a PC and an U-disk.



Warning!
Make sure the PV input power is more than 150V (operate the upgrade on a sunny day), otherwise it may result in serious failing during upgrading. If the upgrading is broken off during operation, please ensure the inverter is steadily powered on and reinsert the U-disk.

Upgrading Steps:

- Step1.** Please contact our service support to get the update files, and extract it into your U-disk as follow:
"update\ARM\618.00050.00_Hybrid_X1G3_Manager_VX.XX.XX-XX.usb";
"update\DSP\618.00084.00_Hybrid_X1G3_Master_VX.XX.XX-XXXXXXX";
(Note: Vx.xx is version number, xxxxxxxx is file completion date. Don't modify the program file name, or it may cause that the inverter can't work anymore!)
- Step2.** Press the "Enter" key for 5 seconds to enter Off Mode. Then unscrew the waterproof lid and insert U-disk into the "upgrade" port at the bottom of the inverter.
- Step3.** The LCD will be shown as the picture below. Then press up and down to select the one that you want to upgrade and press "OK" to confirm to upgrade.

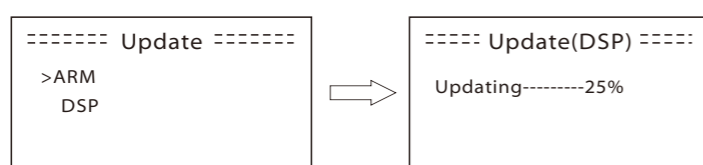

Step4. After the upgrade is finished, the LCD will display "succeed"(only for DSP upgrades), please remember to pull off the U-disk, screw the waterproof lid and press the "Esc" to return to the Main interface. Then press the "Enter" key to exit Off Mode.