



Powerful
Robust
Quiet

CY-450

Delivers **real power** in
everyday winds

marine & industrial off-grid

CY-450 Features



CY-450

The **most powerful turbine** on the market today for its size

High outputs

105W at 8m/s (17.8mph), 450W max

Power in everyday winds

In the cruising winds of 8 - 15 knots, 4 - 8m/s on land

Excellent value for money

Delivers the highest output for the lowest cost

Easy to install

Perfect where space is at a premium - yachts, telecoms towers and CCTV stations.

Robust

Designed for marine environments

Quiet

Quieter than the competition

Appreciated for being quiet thanks to our blade design

The CY-450 is the most powerful turbine of its size, able to provide meaningful power at everyday wind speeds, whilst being tough and robust enough to withstand storm force winds.

The CY-450's excellent power production stems from an exceptionally low start-up wind speed and superior transfer of power from the wind in everyday winds of 5-8m/s (11-18mph).

By fine tuning the characteristics of the alternator to work in perfect harmony with the operating parameters of the five rotor blades, the turbine can extract the right amount of torque, at the right RPM

at a given wind speed, delivering a highly efficient transfer of power from the wind.

The CY450 is precision engineered in the UK with only two moving parts so little maintenance is required during the turbine's long operating life. It is marine quality finished - the aluminium alloy chassis and stainless steel components are protected from the elements with aerospace grade coatings and anodising.

CY-450 Technical Overview

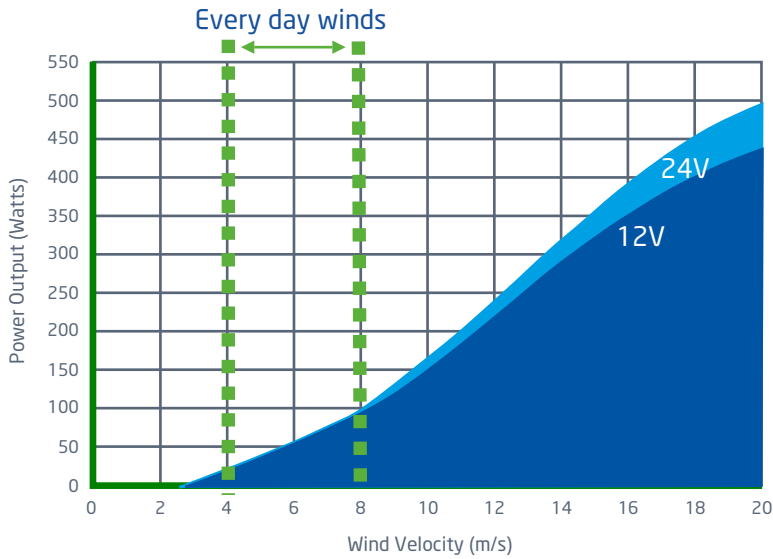

- Rotor diameter** - 1 metre
- Rotor Type** - 5-Blade upwind
- Blade Material** - Glass Reinforced, UV resistant Nylon
- Rated output** - 105W at 8m/s (18mph, 15.5knots)
- Peak output** - 450W
- Cut-in speed** - 3m/s (6.7mph, 6knots)
- Cut-out speed** - None
- Weight** - 8Kg
- Voltages** - 12V, 24V, 48V DC, Grid-tie
- Warranty** - 2 years

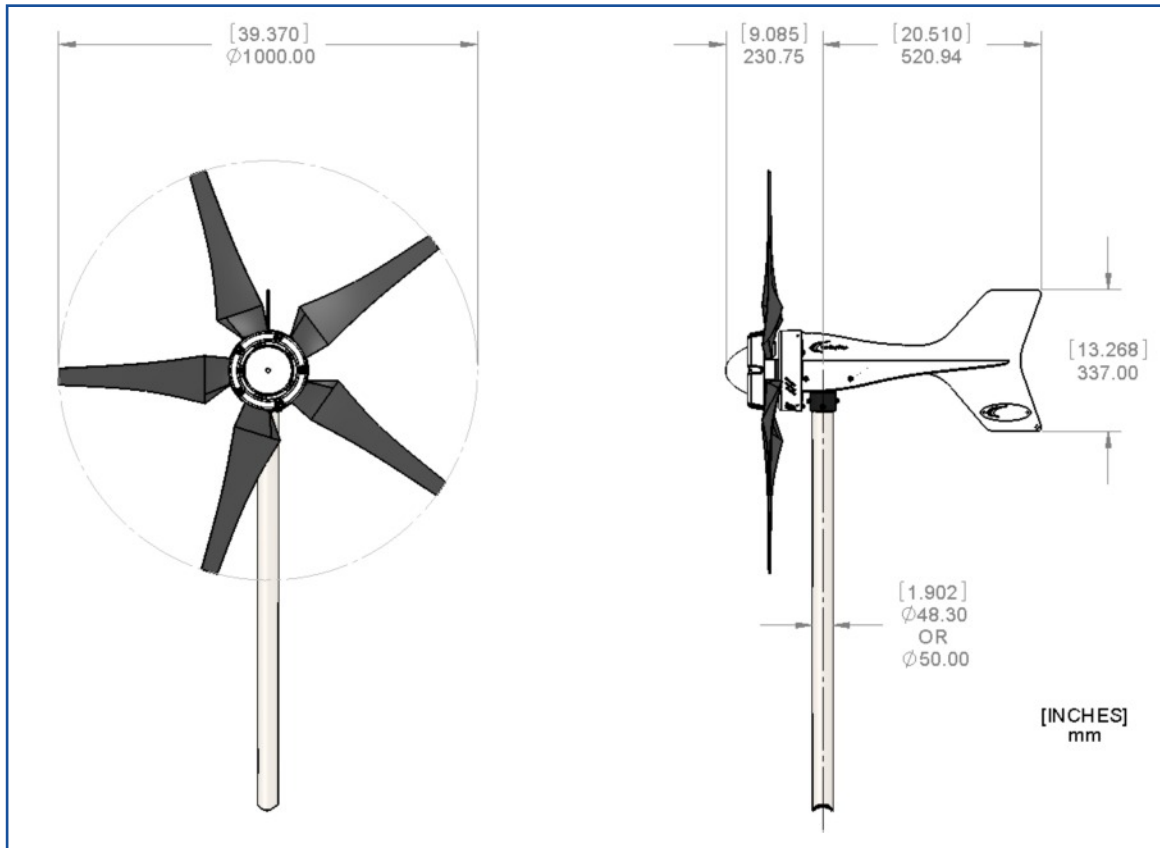

- Rotational speed** - 0-2000 rpm
- Swept area** - 0.785m²
- Tip speed ratio** - 6
- Typical noise level** - 6dB(A) above background
- Alternator type** - Direct drive, axial flux, 8 pole permanent magnet generator
- Design** - 3-phase AC with rectification
- Mounting** - 48.3mm/50mm outer diameter pole

- Materials** - Aluminium alloy chassis, aerospace grade surface finish, epoxy coated stator coils, sealed bearings
- Control system** - Stall regulation
- Brake system** - Electromagnetic braking switch
- Yaw system** - Heavy duty slip ring assembly, 1043mm turning circle

CY-450 Applications



- Marine
- Security
- Telecommunications
- LED Lighting systems
- Road signage
- Telemetry



Our CY-450 horizontal axis turbine addresses the increasing demand for power on small scale off-grid renewable energy systems and grid connected applications. It is as much at home on land as on the water in a variety of applications.